



**DEPARTMENT OF EARLY CHILDHOOD EDUCATION  
M.A.T. (MASTER OF ARTS IN TEACHING)  
PROGRAM REQUIREMENTS**

**ADMISSION TO CANDIDACY (Decision Point 1)**

The student must apply for Regular Admission **no later than July 21, 2008 at 5:00 p.m.**<sup>1</sup> Requirements include:

1. Application for Candidacy (available in the Department of ECE, UH Room 269).
2. Evidence of an activated LiveText account by earning a B or higher in EDUC 6100.
3. Earn a passing score on the GACE Basic Skills exam or meet exemption requirements (see <http://www.education.armstrong.edu/>).
4. Submit electronically two professional disposition assessments from Education faculty. Written requests to faculty members through LiveText must be submitted at least two weeks before the application due date.
5. Completion of EDUC 6000 and EDUC 6100 with a B or better, a C or better in EDUC 6200, and an overall 3.0 GPA in EDUC 6000, EDUC 6100, and EDUC 6200.
6. Two letters of recommendation which address personal demeanor with peers and/or students and parents and candidate initiative and responsibility for his or her learning.
7. Proof of instructional liability insurance by August 31, 2008 (available in the Department of ECE, UH Room 269). If renewed online, please attach the membership receipt to the application, or the Employment Verification form as a substitution for this requirement.
8. An earned 3.0 GPA (overall) in the last 60 hours of undergraduate work.

**Submit all required papers in one packet to Dr. Elizabeth Crawford, Graduate Program Coordinator, University Hall Room 258, by July 21, 2008 at 5:00 p.m.** Student will receive written notification of acceptance to Candidacy. Registration will begin August 14, 2008 for Fall, 2008 classes.



**ADMISSION TO INTERNSHIP (Decision Point 2)**

1. Register for ECMT 6750 during open registration.
2. Submit an application for Graduate Internship **no later than October 31, 2008** to UH 269. The application is available from the Office of Field Experiences, Clinical Practices, & Partnerships website (see <http://www.education.armstrong.edu/fecpp/>).
3. Submit electronically two professional disposition assessments from Education faculty different from those used for Decision Point 1. Written requests to faculty members through LiveText must be submitted at least two weeks before the application due date.

**PROGRAM COMPLETION (Decision Point 3)**

1. Submit in LiveText the Professional Teaching Portfolio by April 1, 2009 or November 1, 2009 in LiveText if completing degree requirements in August, 2009 or December, 2009, respectively.
2. Submit electronically two professional disposition assessments from Education faculty different from those used for Decision Point 1 and 2. Written requests to faculty members must be submitted at least two weeks before the application due date.
3. Show evidence of taking the GACE Content Assessment in Early Childhood Education [Test I (001) and Test II (002)]. (Note: To be eligible for Georgia T-5 certification, the candidate must pass this assessment).

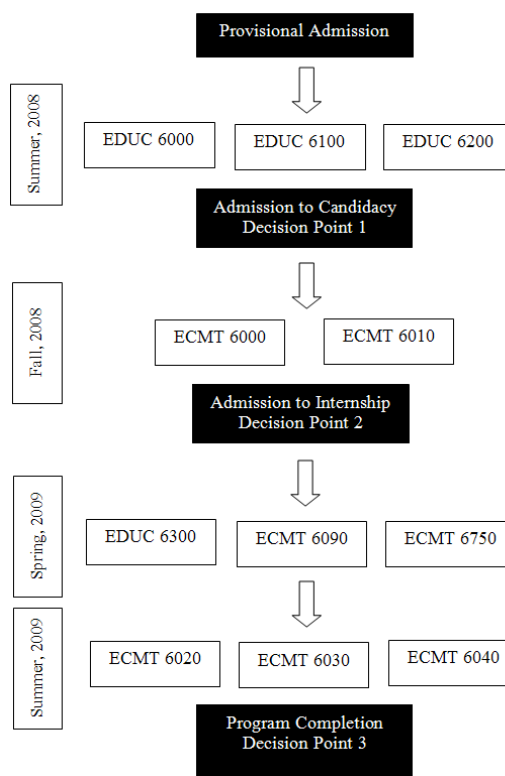

**Important Notes:**

1. Students must maintain a cumulative grade point average of 3.0 or better throughout their M.A.T. Program of Study with a C or better in all coursework. (Exception: Must earn a B or better in EDUC 6000 and EDUC 6100).
2. Students are responsible for applying for graduation two semesters prior to one's anticipated semester of program completion. Forms are available in UH Room 269.
3. Upon completion of the program requirements, the student is responsible for applying for Georgia licensure at <https://www.gapsc.com/Download/Application.pdf>. The student must also send an official AASU transcript to Ms. Kathy Driggers, Certification Officer, UH 250, who makes the recommendation to the Georgia Department of Education that the student be licensed. (Note: A meeting will be held to explain this process).
4. Students assume primary responsibility for knowledge of and compliance with program requirements. Questions should be directed to the student's advisor and/or to the Graduate Program Coordinator.

<sup>1</sup> If a student is denied Regular Admittance to Candidacy, his or her program completion will be delayed.